

Ln#	Trim	Dist.	Item
M5	21'0"	41'7"	CYC TOP PIPE
M4	40'0"	35'0"	CYCLORAMA
24	40'0"	32'5"	BLACK SCRIM
23	0'0"	31'1"	FS BLACK
22	35'0"	29'9"	LEGS 4
21	19'0"	28'1"	3RD ELECTRIC
20	27'2"	26'4"	EL'S BORDER
19	2'3"	24'1"	SCENIC PULLY
18	23'2"		EMPTY
17	22'4"		EMPTY
16	35'0"	21'0"	LEGS 3
15	27'2"	20'1"	23' BORDER 3
14	19'2"		EMPTY
13	N/A	18'2"	FOCUS TRACK
12	19'0"	17'2"	2ND ELECTRIC
11	0'0"	16'2"	SOUND
10	35'0"	15'2"	LEGS 2
9	27'2"	14'3"	25' BORDER 2
8	13'2"		EMPTY
7	12'1"		EMPTY
6	11'3"		EMPTY
5	2'3"	10'2"	SOUND
4	35'0"	9'1"	LEGS 1
3	32'5"	8'2"	27' BORDER 1
2	N/A	7'2"	FOCUS TRACK
1	24'0"	6'6"	1ST ELECTRIC
M3	23'10"	3'8"	LIGHT TRUSS
M2	0'0"	2'6"	HARD TORM
M1	29'6"	2'0"	HARD TEASER
0	0'0"	1'3"	MAIN RAG
00	N/A	0'0"	FIRE CURTAIN

**INSTRUMENT KEY**

**ACCESSORIES**

- 18" Sidearm
- 10" 4 Panel Barn Door
- Source4 A Template Holder

**TYPICAL**

- GENERAL NOTES**
- PLEASE PROVIDE SPARE CUTS OF R119 AND R132 AT FOCUS
  - ALL LIGHTS ON BOOMS TO BE SIDEARMED.
  - DO NOT MAKE ANY ALTERATIONS WITHOUT PERMISSION FROM LIGHTING DESIGNER.
  - ALL SILK SHOULD HAVE LINES VERTICAL AND SPREAD HORIZONTAL.
  - BOOM DIMENSIONS ARE TO THE CENTER OF THE FIXTURE.
  - ELECTRIC DIMENSIONS ARE TO THE C-CLAMP.
  - BOOMS SHOULD BE AS CLOSE AS THEY CAN BE TO THE SPRUNG FLOOR.
  - PAR BOTTLES SHOULD BE SL TO SR.
  - ALL TAILS OF LED FIXTURES SHOULD BE US.

THIS DRAWING REPRESENTS VISUAL CONCEPTS ONLY. THE DESIGNER IS UNQUALIFIED TO DETERMINE STRUCTURAL APPROPRIATENESS OF HIS/HER DESIGN AND WILL NOT ASSUME ANY RESPONSIBILITY FOR INAPPROPRIATE ENGINEERING, CONSTRUCTION, RIGGING, HANDLING OR USE OF THESE IDEAS. ALL MATERIALS AND APPLICATIONS MUST COMPLY WITH THE MOST RIGOROUS FEDERAL, STATE, AND LOCAL FIRE AND SAFETY CODES.



US PIT LIGHT

BOOM COLOR	FRAME OF REFERENCE	TAKE IT TO THE CYPHER	GOOD GIRL	SHUND	CHRONIC TRANSLATION
TXTR	R27	N/C	N/C	N/C	N/C
HEAD	N/C	N/C	L733	R3202	R3202
MID	N/C	N/C	R302	R302	N/C
SHIN	N/C	N/C	R60	N/C	N/C

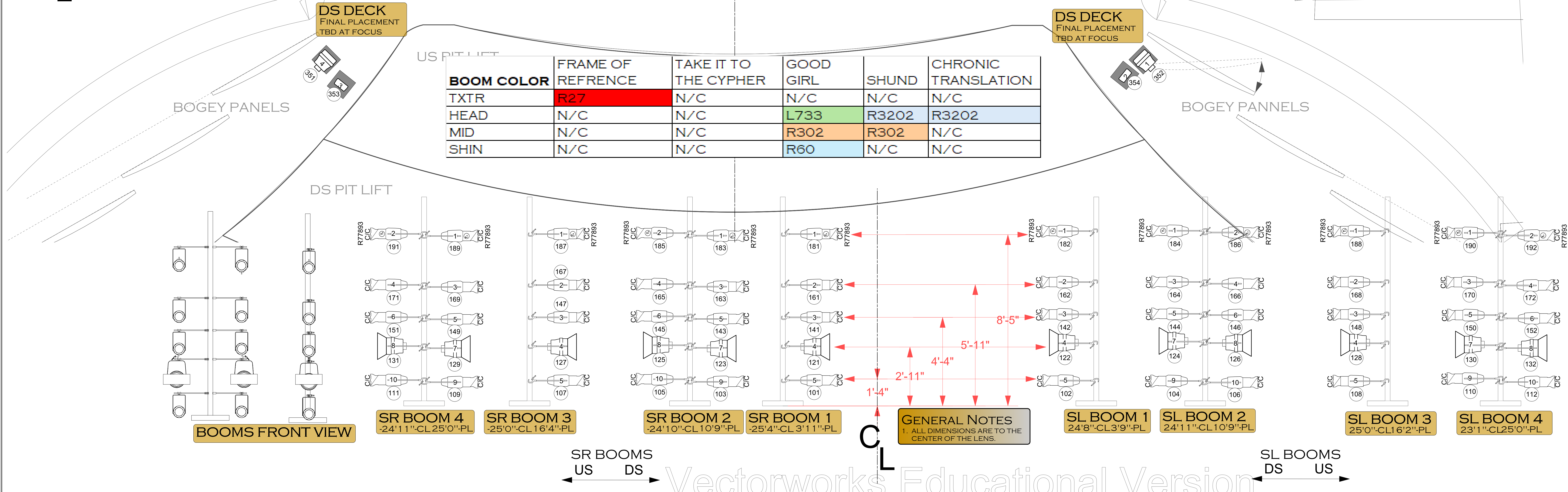

**TRYON FESTIVAL THEATRE**

**LIGHTING DESIGNER**  
KYLE WURTZ  
KYLE.WURTZLD@GMAIL.COM  
(909) 904-5327

**ASSISTANT LIGHTING DESIGNER**  
ROBERT KAYLOR  
RKAYLOR3@ILLINOIS.EDU | (217) 926-6733

**HEAD ELECTRICIAN**  
TRINITY NETT  
TNETT2@ILLINOIS.EDU

**LIGHTING SUPERVISOR**  
LISA KIDD  
LISAKIDD@ILLINOIS.EDU

**ASST. LIGHTING SUPERVISOR**  
DAVID KRUPLA  
KRUPLA2@ILLINOIS.EDU

**STAGE PLOT**

**SHOW TEAM**

PRODUCERS: DANCE@ILLINOIS	DATE: 12/06/2024
PRODUCTION MANAGER: CAPRI AGRESTA	SCALE: 0'1/2"=1'0"
TECHNICAL DIRECTOR: CAPRI AGRESTA	PLATE NO. 1
CONCERT DIRECTORS: JACOB HENNS & PAIGE CUNNINGHAM	OF 3
COSTUME DESIGNER: NICHOLAS DUDIT	DRAFTER: KCW
SOUND DESIGNER: DANIELLA BROWN	
PROPERTIES DESIGNER: EMERY SMITH	
MEDIA DESIGNER: DANIELLE JOHNSON	
STAGE MANAGER: JOSHUA K. STENGER	

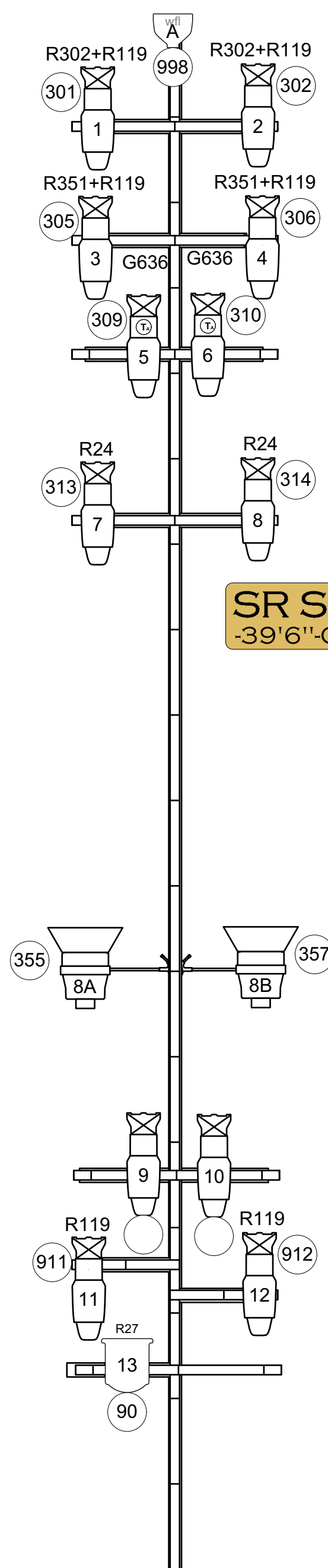

**SR SIDE SLOT**  
-39'6"-CL -31'11"-PL

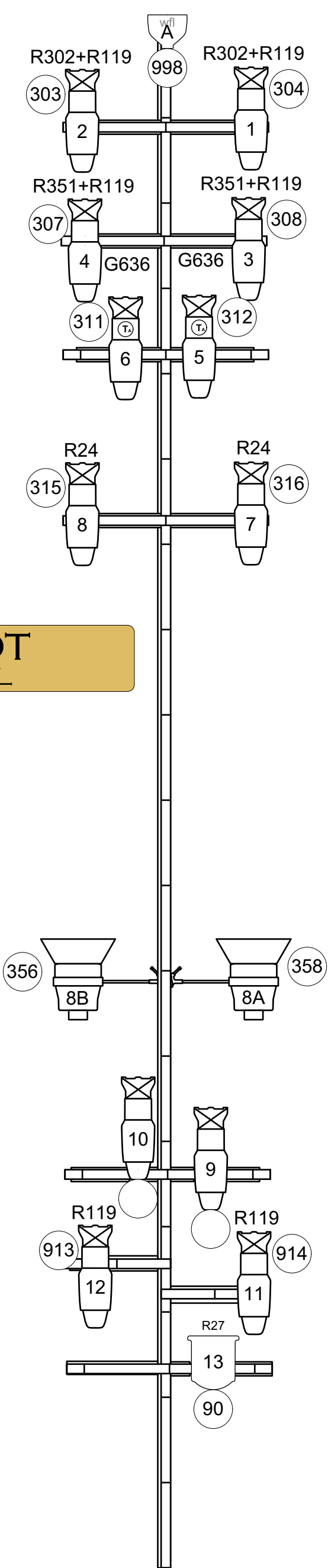
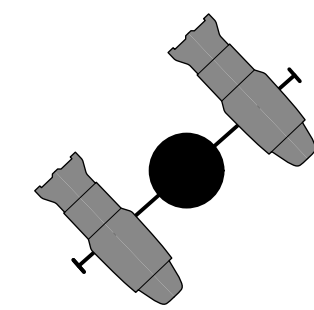
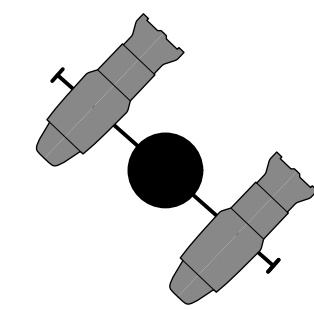

**SL SIDE SLOT**  
39'6"-CL -31'11"-PL

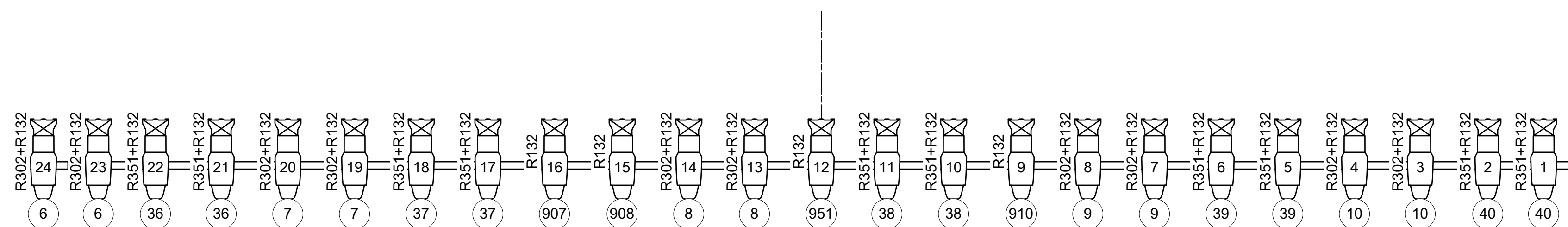

**1ST CEILING SLOT**  
TRIM: 32'5" PL-21'6"

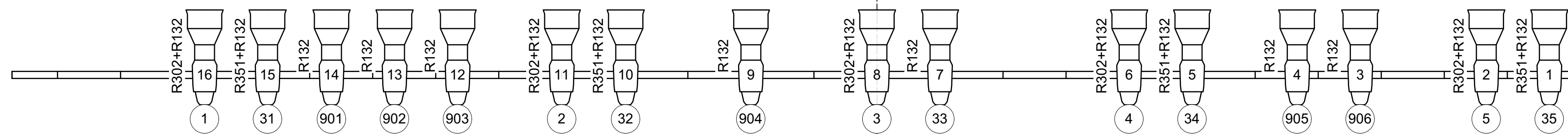
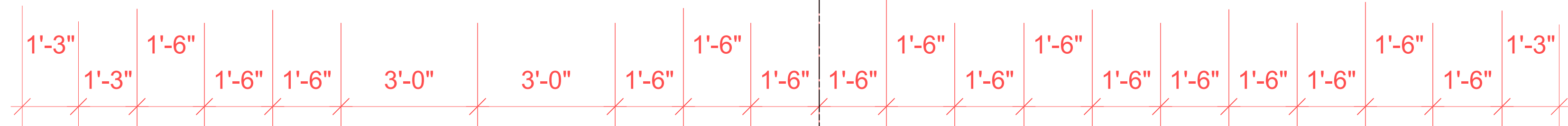

**2ND CEILING SLOT**  
TRIM: 40'0" PL-53'6"

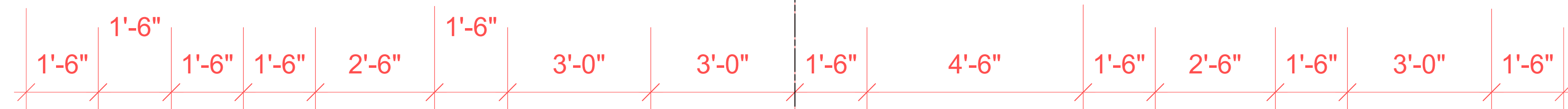

INSTRUMENT KEY	
	ETC Source4 10deg @ 575w
	ETC Source4 19deg @ 575w
	ETC Source4 26deg @ 575w
	Chauvet COLORado 3 Solo @ 187w
ACCESSORIES	
	18" Sidearm
	10" 4 Panel Barn Door
	Source4 A Template Holder
TYPICAL	
	R77774 ← GOBO
	R132+R302 ← COLOR
	← GOBO SYMBOL
	10 ← UNIT NUMBER
	999 ← CHANNEL
	999 ← DIMMER

- GENERAL NOTES**
- PLEASE PROVIDE SPARE CUTS OF R 119 AND R 132 AT FOCUS.
  - ALL LIGHTS ON BOOMS TO BE SIDARMED.
  - DO NOT MAKE ANY ALTERATIONS WITHOUT PERMISSION FROM LIGHTING DESIGNER.
  - ALL SILK SHOULD HAVE LINES VERTICAL AND SPREAD HORIZONTAL.
  - BOOM DIMENSIONS ARE TO THE CENTER OF THE FIXTURE.
  - ELECTRIC DIMENSIONS ARE TO THE C-CLAMP.
  - BOOMS SHOULD BE AS CLOSE AS THEY CAN BE TO THE SPRUNG FLOOR.
  - PAR BOTTLES SHOULD BE SL TO SR.
  - ALL TAILS OF LED FIXTURES SHOULD BE US.

THIS DRAWING REPRESENTS VISUAL CONCEPTS ONLY. THE DESIGNER IS UNQUALIFIED TO DETERMINE STRUCTURAL APPROPRIATENESS OF HIS/HER DESIGN AND WILL NOT ASSUME ANY RESPONSIBILITY FOR INAPPROPRIATE ENGINEERING, CONSTRUCTION, RIGGING, HANDLING OR USE OF THESE IDEAS. ALL MATERIALS AND APPLICATIONS MUST COMPLY WITH THE MOST RIGOROUS FEDERAL, STATE, AND LOCAL FIRE AND SAFETY CODES.

**FEBRUARY DANCE 2024**



**TRYON FESTIVAL THEATRE**

LIGHTING DESIGNER	
KYLE WURTZ KYLE.WURTZLD@GMAIL.COM (909) 904-5327	
ASSISTANT LIGHTING DESIGNER ROBERT KAYLOR RKAYLOR3@ILLINOIS.EDU   (217) 926-6733	
HEAD ELECTRICIAN TRINITY NETT TNETT2@ILLINOIS.EDU	
LIGHTING SUPERVISOR LISA KIDD LISAKIDD@ILLINOIS.EDU	ASST. LIGHTING SUPERVISOR DAVID KRUPLA KRUPLA2@ILLINOIS.EDU

**FOH PLOT**

SHOW TEAM	
PRODUCERS: DANCE@ILLINOIS	DATE
PRODUCTION MANAGER: CAPRI AGRESTA	12/06/2024
TECHNICAL DIRECTOR: CAPRI AGRESTA	SCALE
CONCERT DIRECTORS: JACOB HENNS & PAIGE CALDARELLA	0'1/2"=1'0"
COSTUME DESIGNER: NICHOLAS DUDIT	PLATE NO.
SOUND DESIGNER: DANIELLA BROWN	2
PROPERTIES DESIGNER: EMERY SMITH	OF
MEDIA DESIGNER: DANIELLE JOHNSON	3
STAGE MANAGER: JOSHUA K. STENGER	DRAFTER
	KCW

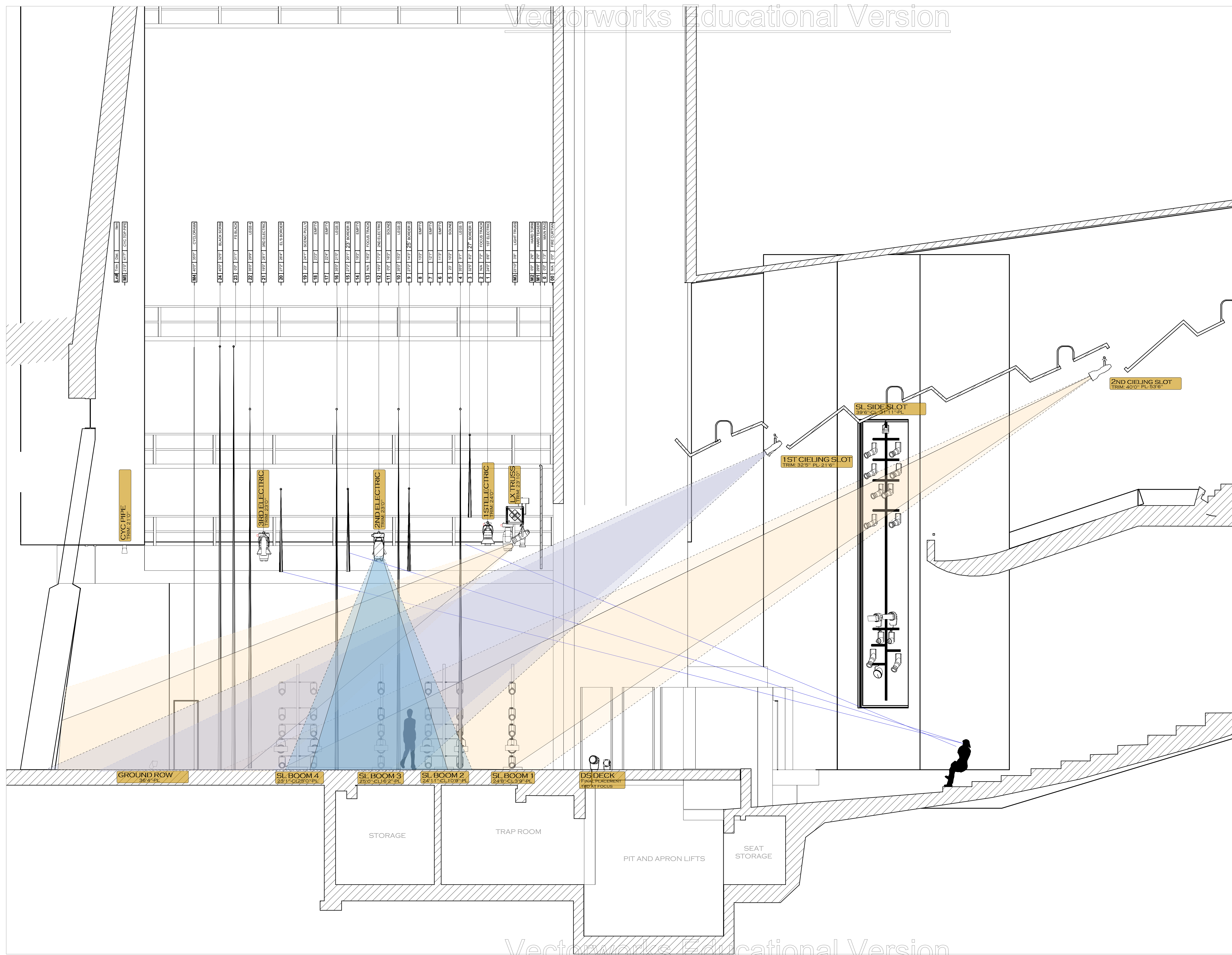

ACCESSORIES	
	18" Sidearm
	10" 4 Panel Barn Door
	Source4 A Template Holder

TYPICAL	
	R7774
	R132+R302
	GOGO
	COLOR
	GOGO SYMBOL
	UNIT NUMBER
	CHANNEL
	DIMMER

**GENERAL NOTES**

- PLEASE PROVIDE SPARE CUTS OF R 119 AND R 132 AT FOCUS.
- ALL LIGHTS ON BOOMS TO BE SIDEARMED.
- DO NOT MAKE ANY ALTERATIONS WITHOUT PERMISSION FROM LIGHTING DESIGNER.
- ALL SILK SHOULD HAVE LINES VERTICAL AND SPREAD HORIZONTAL.
- BOOM DIMENSIONS ARE TO THE CENTER OF THE FIXTURE.
- ELECTRIC DIMENSIONS ARE TO THE C-CLAMP.
- BOOMS SHOULD BE AS CLOSE AS THEY CAN BE TO THE SPRUNG FLOOR.
- PAR BOTTLES SHOULD BE SL TO SR.
- ALL TAILS OF LED FIXTURES SHOULD BE US.

THIS DRAWING REPRESENTS VISUAL CONCEPTS ONLY. THE DESIGNER IS UNQUALIFIED TO DETERMINE STRUCTURAL APPROPRIATENESS OF HIS/HER DESIGN AND WILL NOT ASSUME ANY RESPONSIBILITY FOR INAPPROPRIATE ENGINEERING, CONSTRUCTION, RIGGING, HANDLING OR USE OF THESE IDEAS. ALL MATERIALS AND APPLICATIONS MUST COMPLY WITH THE MOST RIGOROUS FEDERAL, STATE, AND LOCAL FIRE AND SAFETY CODES.



**FEBRUARY DANCE 2024**

TRYON FESTIVAL THEATRE	
<b>LIGHTING DESIGNER</b>	
KYLE WURTZ KYLE.WURTZLD@GMAIL.COM (909) 904-5327	
<b>ASSISTANT LIGHTING DESIGNER</b>	
ROBERT KAYLOR RKAYLOR3@ILLINOIS.EDU   (217) 926-6733	
<b>HEAD ELECTRICIAN</b>	
TRINITY NETT TNETT2@ILLINOIS.EDU	
<b>LIGHTING SUPERVISOR</b>	<b>ASST. LIGHTING SUPERVISOR</b>
LISA KIDD LISAKIDD@ILLINOIS.EDU	DAVID KRUPLA KRUPLA2@ILLINOIS.EDU

SECTION	
<b>SHOW TEAM</b>	
PRODUCERS: DANCE@ILLINOIS	DATE: 12/06/2024
PRODUCTION MANAGER: CAPRI AGRESTA	SCALE: 0'1/2"=1'0"
TECHNICAL DIRECTOR: CAPRI AGRESTA	PLATE NO. 3
CONCERT DIRECTORS: JACOB HENNS & PAIGE CALDARELLA	OF 3
COSTUME DESIGNER: NICHOLAS DUDIT	DRAFTER: KCW
SOUND DESIGNER: DANIELLA BROWN	
PROPERTIES DESIGNER: EMERY SMITH	
MEDIA DESIGNER: DANIELLE JOHNSON	
STAGE MANAGER: JOSHUA K. STENGER	

# FEBRUARY DANCE 2024 MAGIC SHEET

LIGHTING BY KYLE WURTZ

